

MotorGuide REPAIR PARTS

Model: **POWERplus**
QS36V

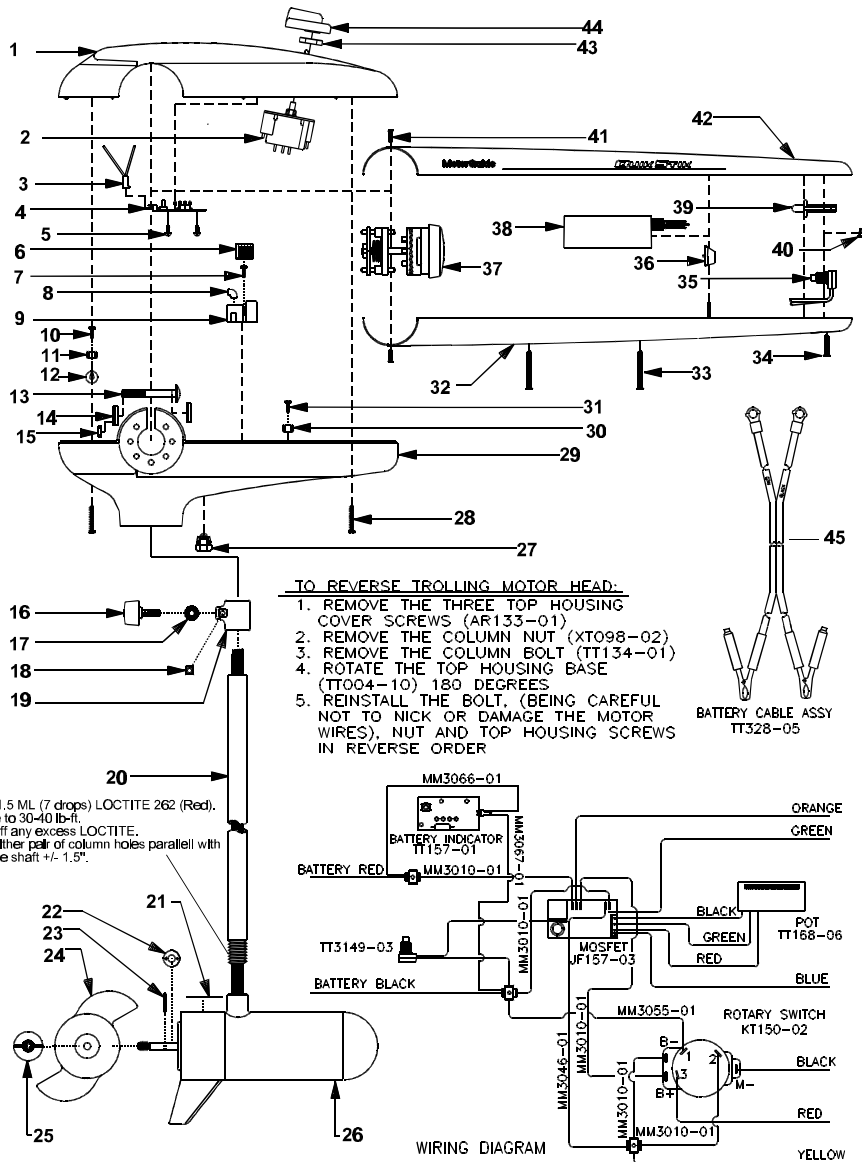

TO REVERSE TROLLING MOTOR HEAD:
 1. REMOVE THE THREE TOP HOUSING COVER SCREWS (AR133-01)
 2. REMOVE THE COLUMN NUT (XT098-02)
 3. REMOVE THE COLUMN BOLT (TT134-01)
 4. ROTATE THE TOP HOUSING BASE (TT004-10) 180 DEGREES
 5. REINSTALL THE BOLT, (BEING CAREFUL NOT TO NICK OR DAMAGE THE MOTOR WIRES), NUT AND TOP HOUSING SCREWS IN REVERSE ORDER

-Apply 1.5 ML (7 drops) LOCTITE 262 (Red).
 -Torque to 30-40 lb-ft.
 -Wipe off any excess LOCTITE.
 -Align either pair of column holes parallel with armature shaft +/- 1.5".

NOTE: INSULATING SLEEVE AT080-01, GOES ON ORANGE AND BLACK (TERMINAL B) WIRES ON MOSFET BOARD.

SPECIFICATIONS:
 Year of Intro 1998
 Thrust 36LBS
 Volts 12VDC
 Amp Draw 0 to 48 amps
 Mount 09 Transom
 Speeds Variable

QUICK REFERENCE PARTS GUIDE:
 Rotary Switch KT150-02
 ON/OFF Switch TT3149-03
 DA Board JF157-03
 MOSFET JF096-07
 Motor Seal Kit 6220
 Slide Pot TT168-06

PARTS ORDERING & TECH ASSISTANCE
 MotorGuide Consumer Relations
 Phone 918-831-6989
 Fax 800-982-8093
Send Returned Goods to:
 MotorGuide
 605 Hwy 12 West
 Starkville, MS 39760

Returned Goods must be accompanied with a Returned Goods Authorization. Contact MotorGuide Consumer Relations to obtain RGA.

KEY#	PART#	DESCRIPTION	KEY#	PART#	DESCRIPTION
1	TT053-10	COVER 5 SPD QS GENERIC	26	SF397-01	LOWER UNIT
2	KT150-02	ROTARY SWITCH	27	GR019-01	BATTERY CABLE BUSHING
3	WF329-01	CONNECTOR/JUMPER ASY	28	AR133-01	8 X 1 3/8 SCREW
4	TT157-01	BATTERY LEVEL INDICATOR	29	TT004-10	T/H BASE GENERIC
5	AF141-01	SELF TAPPING SCREW	30	FT160-03	TERMINAL 4 PRONG
6	AP029-01	AMP CONNECTOR	31	GR133-01	310 X 1/2 SCREW
7	AF141-01	SELF TAPPING SCREW	32	TT072-05	LOWER HANDLE QS BLACK
8	AT080-01	INSULATING SLEEVE	33	TT133-03	#6 X 1" SCREW
9	JF157-03	12V DURA AMP BOARD	34	TT133-02	#6 X .75 SCREW
10	GR133-01	310 X 1/2 SCREW	35	TT3149-03	ON/OFF SWITCH ASY
11	FT160-03	TERMINAL (4 PRONG)	36	TT3001-03	ACTUATOR ASY
12	TT098-03	ON SERT PAL NUT	37	TT372-04	HANDLE CLUTCH ASY
13	TT134-01	BOLT	38	TT168-06	POTENTIOMETER
14	TT171-04	CURVED WASHER	39	TT001-04	ACTUATOR ON/OFF
15	XT098-02	NYLON LOCK NUT	40	TT177-02	SWITCH BOOT
16	AR082-02	BAR KNOB DEPTH ADJUST	41	TT133-01	#6 X .437 SCREW
17	AR171-01	COLUMN CLAMP WASHER	42	TT072-12	UPPER HANDLE
18	FR098-01	COLUMN SUPPORT NUT	43	AT098-01	PAL NUT
19	AR051-01	DEPTH ADJUST COLLAR	44	TT082-06	ROTARY KNOB
20	TT049-04	COLUMN 30"	45	TT328-05	BATTERY CABLE ASY
	FR049-15	COLUMN 42"			
21	ET060-04	LOWER UNIT DECAL			
22	AR175-01	MONOFILAMENT WASHER			
23	BR102-01	PROP PIN			
24	AF124-10	3 BLADE PROP			
25	AR099-01	PROP NUT			

PARTS NOT ILLUSTRATED
 NT056-10 DECAL
 MM5604 OWNERS MANUAL

Model:
QS36V

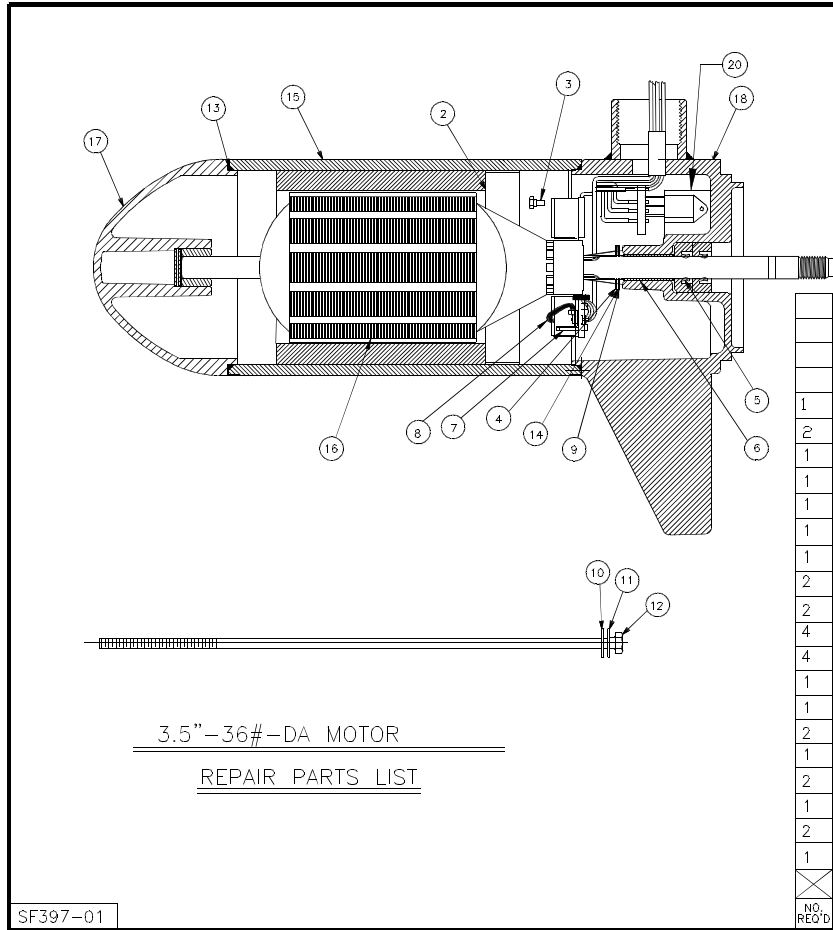

NOTE - TORQUE THRU BOLT, BOLT, PART MR218-14, AND DURA AMP SCREW, PART MR229-02, TO 35-40 LB-IN

NO. REQ'D	ITEM NO.	DESCRIPTION	PART NO.
	20	DURA AMP MODULE	JF096-07
	19	DURA AMP SCREW	MR229-02
	18	COMM CAP COMPLETE	SF3205-01ASAW
	17	NOSE CAP S/A	JF3212-01BSAW
	16	ARMATURE 3.5"	PF3207-01
	15	HOUSING ASS'Y	PF3210-01ASAW
	14	WASHER	MR227-01
	13	"O"-RING SEAL	MR217-01
	12	THRU BOLT	MR218-14
	11	THRU BOLT WASHER	MR216-01
	10	STATIC SEAL	MR222-01
	9	NYLATRON WASHER	MR226-01
	8	BRUSH ASS'Y-LESS SPRING	JF3201-01
	7	BRUSH SPRINGS	MR214-02
	6	BEARING	MR206-01
	5	SHAFT SEAL	MR223-01
	4	"E" RING	MR219-02
	3	BRUSH CARD SCREW	MR228-01
	2	RETAINER	JF233-01
X	1	3.5"-36#-DA MOTOR	SF397-01

SF397-01

WIRING

